

RESOLUTION NO. 2024-05

A RESOLUTION OF THE TWIN OAKS BOARD OF ALDERMEN APPROVING AN AGREEMENT WITH BEIS PLUMBING LLC FOR REPLACING LAVATORY EQUIPMENT AT THE TWIN OAKS PARK COMFORT STATION.

BE IT RESOLVED BY THE BOARD OF ALDERMEN OF THE CITY OF TWIN OAKS, MISSOURI, AS FOLLOWS:

Section 1. The Board of Aldermen hereby approves, and the Mayor is hereby authorized to execute, the City Services Contract with Beis Plumbing LLC for removing the existing toilet in the men's restroom at Twin Oaks Park and installing a new Kohler K-4386 model toilet for a total price not to exceed \$1,355.00 substantially in the form of the Agreement attached hereto as "Exhibit 1" and incorporated herein by reference.

Section 2. This Resolution is adopted and shall be in full force and effect on and after its passage and approval.

THIS RESOLUTION WAS PASSED AND APPROVED THE 7th DAY OF FEBRUARY 2024, BY THE BOARD OF ALDERMEN OF THE CITY OF TWIN OAKS, MISSOURI.

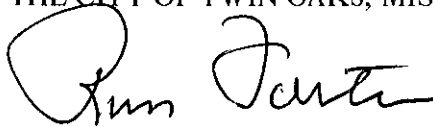

Russ Fortune, Mayor

Attest:

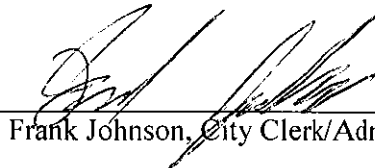

Frank Johnson, City Clerk/Administrator

Exhibit 1

Twin Oaks, Missouri CONTRACTOR SERVICES CONTRACT

THIS AGREEMENT, made and effective as of _____ by and between the **City of Twin Oaks, Missouri**, a municipal corporation hereinafter referred to as the "City," and **Beis Plumbing LLC**, a Missouri corporation, hereinafter referred to as "Contractor," with a business mailing address of 280 Vance Road, Valley Park, MO 63088.

WHEREAS, the Contractor provided the City with the proposal, attached hereto as **Exhibit A** and incorporated herein by reference, for removing the existing toilet in the men's bathroom at Twin Oaks Park and installing a new Kohler K-4386 model toilet, as described on Exhibit A (the "Proposal"), and the City wishes to engage the Contractor as provider of those services to the City, in accordance with the terms of this Agreement;

WITNESSETH: That the parties hereto for the considerations hereinafter set forth agree as follows:

I. SCOPE OF SERVICES

Contractor's services are necessary for the following Project of City: *Installation of new toilet in the men's bathroom facility in Twin Oaks Park.*

Except as expressly specified herein, Contractor hereby agrees to provide the expertise, supplies, supervision, labor, skill, materials, equipment, and apparatus to perform all the services and do all the things necessary for the proper completion of the scope of services for the Project listed above and as more particularly described in the "Scope of Work" set forth in the attached **Exhibit A**.

The above-referenced services (hereinafter referred to as the "Work") shall be provided by the Contractor in accordance with all the provisions of the Proposal and the attached **Twin Oaks General Conditions** which are incorporated herein by reference, and the terms of the General Conditions shall prevail over any conflicting terms that may otherwise be adopted herein as part of any attachment, including the Proposal. If there is any conflict between the City's General Conditions (attached hereto and incorporated herein by reference) and the Proposal, this Agreement and its General Conditions shall prevail.

II. COMPENSATION

A. **Basic Compensation.** The City hereby agrees to pay the Contractor as set forth below, as full compensation upon the completion of the Work:

Due at the City's final acceptance of the Work: \$1,355.00

III. TIME AND MANNER OF PAYMENTS

All invoices complete with necessary support documentation shall be submitted to the City and payment shall be made by City within thirty (30) days of receipt of an invoice received after satisfactory performance of the Work for the fees, prices, rates, or schedule of values set forth below.

IV. CONTRACT SCHEDULE

Time is of the essence. The Work shall be commenced on _____ and shall be completed in a reasonable manner no later than _____. Failure to complete the Work by the completion date shall result in a reduction in the amount due to the Contractor under this Contract in the amount of

\$100.00 per day as liquated damages, herein acknowledged to be reasonable compensation for such delay, in addition to any other remedy that the City may have hereunder.

IN WITNESS WHEREOF, the parties hereto have signed this Agreement as of the effective date of Contract first above written.

BEIS PLUMBING LLC

CITY OF TWIN OAKS

By _____

By _____

Title _____

Title _____

DATED: _____

DATED: _____

ATTEST: _____

City Clerk

GENERAL CONDITIONS
CITY OF TWIN OAKS, MISSOURI
CONTRACTOR SERVICES AGREEMENT

Independent Contractor. The Contractor shall be and operate as an independent contractor in the performance of this Contract. The Contractor shall have complete charge of the personnel engaged in the performance of the Work, and all persons employed by the Contractor shall be employees of said Contractor and not employees of the City in any respect.

Compliance with Laws. The Contractor shall comply with all applicable City ordinances and other laws and regulations, Federal, State, and any political subdivision thereof, including but not limited to, unemployment and workers' compensation, occupational safety, equal employment and affirmative action and wage and price laws insofar as applicable to the performance of the Contract. Specifically, Contractor shall comply with the following state law requirements:

- *Proof of Lawful Presence.* Section 208.009 RSMo., requires that all applicants *at the time of application* for any contract provided by a local government provide "affirmative proof that the applicant is a citizen or a permanent resident of the United States or is lawfully present in the United States." Contractor's affirmative proof must be established through (i) a Missouri driver's license, (ii) any "documentary evidence recognized by the department of revenue when processing an application for a driver's license," or (iii) "any document issued by the federal government that confirms an alien's lawful presence in the United States." §208.009.3.

Subcontracts. The Contractor shall not subcontract any of the Work to be performed by it hereunder without the express written consent of the City. In addition, this Contract shall not be assigned by the Contractor.

Indemnification. To the fullest extent permitted by law, the Contractor agrees to defend with counsel selected by the City, and indemnify and hold harmless the City, its officers, engineers, representatives, agents and employees from and against any and all liabilities, damages, losses, claims or suits, including costs and attorneys' fees, for or on account of any kind of injury to person, bodily or otherwise, or death, or damage to or destruction of property, or any other circumstances, sustained by the City or others, arising from Contractor's breach of the Contract or out of services and operations performed hereunder by the Contractor, including the City's reliance on or use of the services or products provided by the Contractor under the terms of this agreement. The Contractor shall not be liable for any loss or damage attributable solely to the negligence of the City. To the extent required by law to enforce this provision, Contractor agrees that this indemnification requires Contractor to obtain insurance in amounts specified herein and that Contractor has had the opportunity to recover the costs of such insurance in the Compensation set forth in this Agreement.

Insurance. Contractor shall furnish the City the certificates of insurance for workers' compensation, public liability, and property damage, including automobile coverage in the amounts specified by the City in the request for proposals, if any, otherwise in the amounts stated on **Exhibit B**, but unless otherwise provided shall be no less than the maximum amounts of liability set forth in Chapter 537.610 RSMo., applicable to political subdivisions. The policies of insurance shall be in such form and shall be issued by such company or companies as may be satisfactory to the City. The City, and such additional persons and entities as may be deemed to have an exposure to liability as a result of the performance of the Contractor's work, as determined by the City, shall be named as additional insured and the applicable insurer shall owe the City a duty of defense on all insurance policies required hereunder. The Contractor shall provide an Additional Insured Endorsement to the City that shall be approved by the City prior to commencement of any Work.

In addition to the foregoing, the Contractor shall maintain Professional Liability "errors and omissions" insurance in the form for the coverages satisfactory to City as indicated in the request for proposals, if any, otherwise as stated on attached **Exhibit B**, if any, but in no event less than the maximum amounts of liability set forth in Chapter 537.610 RSMo. applicable to political subdivisions. The City and Contractor waive all rights against each other for damages caused by fire or other perils to the extent covered by Builder's Risk or any other property insurance, except such rights as they may have to the proceeds of such insurance; provided that nothing herein shall be deemed a waiver of the City's sovereign immunity relative to any claim against the City.

Nondisclosure. The Contractor agrees that it will not divulge to third parties without the written consent of the City any information obtained from or through the City in connection with the performance of this Contract. Nothing herein shall preclude disclosure of information by the City.

Changes. No change in this Contract shall be made except in writing prior to the change in the Work or terms being performed. The Contractor shall make any and all changes in the Work without invalidating this Contract when specifically ordered to do so in writing by the City. The Contractor, prior to the commencement of such changed or revised Work, shall submit promptly to the City, a written cost or credit proposal for such revised Work. If the City and Contractor shall not be able to agree as to the amount, either in consideration of time or money to be allowed or deducted, it shall nevertheless be the duty of Contractor, upon written notice from the City, to immediately proceed with such alteration or change, and Contractor shall be compensated the reasonable value of such Work. **No Work or change shall be undertaken or compensated for without prior written authorization from the City.**

Termination. The City shall have the right to terminate the Contract at any time for any reason by giving the Contractor written notice to such effect. The City shall pay to the Contractor in full satisfaction and discharge of all amounts owing to the Contractor under the Contract an amount equal to the cost of all Work performed by the Contractor up to such termination date, less all amounts previously paid to the Contractor on account of the

Contract Price. The Contractor shall submit to the City its statement for the aforesaid amount, in such reasonable detail as the City shall request, within thirty (30) days after such date of termination. The City shall not be liable to the Contractor for any damages on account of such termination for loss of anticipated future profits with respect to the remainder of the Work.

Multi-year contracts; Non-appropriation. Notwithstanding any provision herein to the contrary, the City is obligated only to make the payments set forth in the attached Contract as may lawfully be made from funds budgeted and appropriated for that purpose during the City's then current fiscal year at the discretion of the City. If no funds are appropriated or otherwise made legally available to make the required payments for this Agreement during the next occurring fiscal year (an "Event of Nonappropriation"), this Agreement will terminate at the end of the then current fiscal year as if terminated expressly. The failure or inability of the City to appropriate funds for this Agreement in any subsequent fiscal year shall not be deemed a breach of this Agreement by any party. If applicable, this Agreement may be annually renewed at each fiscal year by inclusion of specific appropriation for this Agreement, from year to year not to exceed the maximum renewal period or term as set forth in the Agreement.

Accounting. During the period of this Contract, the Contractor shall maintain books of accounts of its expenses and charges in connection with this Contract in accordance with generally accepted accounting principles and practices. The City shall at reasonable times have access to these books and accounts to the extent required to verify all invoices submitted hereunder by the Contractor.

Correction Period. Contractor hereby expressly guarantees the aforesaid Work as to workmanship and quality of materials used in connection herewith for a term of one (1) year, commencing on the date of final acceptance by the City, and binds itself, its successors or assigns, to make all repairs or replacements which may become necessary within said period due to construction defects and nonconformity with the City specifications or contract. The Contractor warrants to the City that all materials and equipment furnished under the Contract and incorporated in the Work will be new unless otherwise specified, and that all Work will be of good quality, free from faults and defects and in conformance with the Contract. The Contractor's general warranty and any additional or special warranties are not limited by the Contractor's obligations to specifically correct defective or nonconforming Work as set forth herein, nor are they limited by any other remedies provided in the Contract.

Request for Proposals. If the City issued a request for proposals in connection with the Work, such request for proposals and the proposal of the Contractor in response thereto are incorporated herein by reference and made a part of this Contract. In case of any conflicts between the request for proposals and the executed Contractor Services Contract or proposal of the Contractor, the requirements of the City's Request for Proposal and this executed Contract shall control and supersede unless a change thereto is specifically stated in this Contract (including **Exhibit A**, "Scope of Work").

Project Records and Work Product. The Contractor shall provide the City with copies of all documents pertinent to the Work which shall include, without limitation, reports, correspondence, meeting minutes, and originals of all deliverables. The City shall own all right, title and interest, including without limitations, all copyrights and intellectual property rights, to all documents and Work Product of the Contractor created in performance of or relating to this Contract. Contractor agrees to take all steps reasonably requested by the City to evidence, maintain, and defend the City's ownership rights in the Work Product.

Site Operations. Where appropriate, the City will arrange for right of entry to any property at the request of the Contractor for the purpose of performing studies, tests and evaluations in connection with the Work.

Personnel. The Work shall be performed exclusively by the personnel of the Contractor identified in the Contractor's proposal and no other personnel of the Contractor shall perform any of the Work without the express written approval of the City.

Representations. Contractor agrees that it has not relied on any representations or warranties of the City, oral or written, other than expressly identified in this Contract. The parties agree the Contract represents the entire agreement between the parties.

Governing/Choice of Law. This Agreement shall be governed by and construed and interpreted in accordance with the internal laws of the State of Missouri, without regard to its principles of conflict of laws.

Other Special Provisions. There are no additional special provisions set forth in the Contractor Services Agreement.

EXHIBIT A
Proposal



Beis Plumbing LLC

Twin Oaks Town Hall
 Twin Oaks Town Hall
 1381 Big Bend Rd
 Ballwin, MO 63021

(314) 574-7152
 jwilliams@cityoftwinoaks.com

ESTIMATE	#10259
ESTIMATE DATE	Nov 6, 2023
TOTAL	\$1,355.00

SERVICE ADDRESS
 1 Twin Oaks Ct
 Manchester, MO 63021

CONTACT US
 280 VANCE ROAD
 VALLEY PARK, MO 63088

(314) 500-5325
 beisplumbing@gmail.com

ESTIMATE

Description	Qty	Unit Price	Amount
Supply/Install New Toilet	1.0	\$1,355.00	\$1,355.00

*This wc needs to be ordered, office, if approved, do not schedule until delivery has been confirmed.

We will remove existing toilet and haul away. We will remove existing censor flush valve from behind wall, censor panel will remain but be disconnected. We will supply and install new chrome Sloan manual flush valve, and wall flush wc, piped through wall into storage room and connected to existing waterline.

1yr warranty on parts and labor supplied and installed by Beis Plumbing.

Disclaimers - Financing	1.0	\$0.00	\$0.00
-------------------------	-----	--------	--------

This makes the option to get all your plumbing wants and needs easier to perform all at once! The average older toilet, faucet, water heater etc. may be costing more than a newer more energy efficient model available. Along with the energy rebates on some units and the on site cost savings by doing more with a trade on site, this may be a great option!

We offer financing through Wisetack, rates as low as 0%, all pending credit and length needed! It is a soft pull with no impact on credit unless you choose to go with it! No credit card, monthly payment, and its closed when paid in full! All services over \$500.00 in cost are eligible for financing!! Ask our office for more details or click the tab on your estimate!!

A frequent source of confusion and concern among customers when applying for a loan is the potential impact on their credit score.

Lenders can conduct two types of credit inquiries when approving a customer — a soft pull or a hard pull. Hard pulls are more common and often impact credit. Soft pulls, on the other hand, do not hurt credit scores.

Managers Info - Service Manager - Dave 1.0 \$0.00 \$0.00

We are always here to answer any of your questions, concerns, or just to talk about the project time line! If you have your info ready, even the estimate number if that is an option, give our guys a direct call and they will take care of all your concerns!

Dave Cell: 636-628-7498

Email: Servicemanager@BeisPlumbing.com

Services subtotal: \$1,355.00

Subtotal \$1,355.00

Total \$1,355.00

REMIT PAYMENT TO:

Beis Plumbing, LLC

280 VANCE RD

VALLEY PARK, MO 63088

Quotes are valid for the next 30 days, after which values may be subject to change.

Thank you for your business. Payment is due at time of service.

There will be a \$35.00 fee for any returned check. There is no warranty through Beis Plumbing for any work done if the house pressure is over 75 PSI. All warranties are void if work is not paid for.

If it is a remodel/new construction, 30% of quote is due after ground rough, 50% of quote is due after wall rough and the final 20% is due after finish. If no ground work then 80% will be due after wall rough and the final 20% is due after finish. Extras will be billed accordingly per segment. If this is not received prior to needing to schedule the next stage, the job will not be added to the schedule until funds are paid in full. If no payment is received within 14 days from the date of service, then Beis Plumbing, LLC reserves the right to charge a late fee.

PLEASE REFER TO TERMS & CONDITIONS

Notice to Owner:

FAILURE OF THIS CONTRACTOR TO PAY THOSE PERSONS SUPPLYING MATERIAL OR SERVICES TO COMPLETE THIS CONTRACT CAN RESULT IN THE FILING OF A MECHANIC'S LIEN ON THE PROPERTY WHICH IS THE SUBJECT OF THIS CONTRACT PURSUANT TO THE CHAPTER 429. RSMO. TO AVOID THIS RESULT YOU MAY ASK THIS CONTRACTOR FOR "LIEN WAIVERS" FROM ALL PERSONS SUPPLYING MATERIAL OR SERVICES FOR THE WORK DESCRIBED IN THIS CONTRACT, FAILURE TO SECURE LIEN WAIVERS MAY RESULT IN YOUR PAYING FOR LABOR AND MATERIAL TWICE. CONTRACTEE AGREES TO PAY SERVICE CHARGE OF 1-1/2% PER MONTH (18% PER YEAR) ON ALL PAST DUE INVOICES. CONTRACTEE AGREES TO PAY ALL COLLECTIONS FEES, LEGAL FEES, AND EXPENSES INCURRED BY BEIS PLUMBING IN CONNECTION WITH OR IN THE COLLECTION OF THIS CONTRACT.
ACCOUNTS WILL BE SENT TO COLLECTIONS AFTER 30 DAYS.

Features

- Vitreous china
- Elongated bowl
- Angle back and wall outlet
- 1-1/2" top spud
- 2-3/8" (60 mm) passageway
- 11" (279 mm) x 9-1/2" (241 mm) water area
- 4-1/2" (114 mm) rough-in
- 1.6 gpf (6.0 lpf)
- 27-1/2" (699 mm) x 14-1/2" (368 mm) x 15" (381 mm)

Codes/Standards Applicable

Specified model meets or exceeds the following:

- CSA B651
- OBC
- ASME A112.19.2/CSA B45.1

ELONGATED TOILET BOWL K-4386

CSA B651 OBC

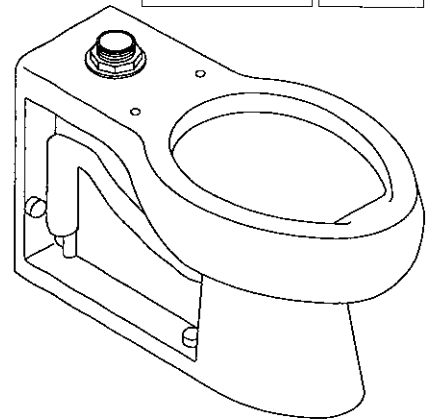

Colors/Finishes

- 0: White
- Other: Refer to Price Book for additional colors/finishes

Accessories

- 0: White
- CP: Polished Chrome
- Other: Refer to Price Book for additional colors/finishes

Specified Model

Model	Description	Colors/Finishes	
K-4386	Elongated toilet bowl	<input type="checkbox"/> 0	<input type="checkbox"/> Other _____
K-4386-L	Elongated toilet bowl - with bedpan lugs	<input type="checkbox"/> 0	<input type="checkbox"/> Other _____

Recommended Accessories			
K-4670-C	Lustra™ open-front seat	<input type="checkbox"/> 0	<input type="checkbox"/> Other _____
K-4670-CA	Lustra open-front seat with anti-microbial agent	<input type="checkbox"/> 0	
K-4679	Lustra open-front seat with anti-microbial agent, less cover	<input type="checkbox"/> 0	
K-10674	WAVE exposed toilet flushometer – 1.6 gpf (6.0 lpf)		<input type="checkbox"/> CP
K-10957	Touchless DC toilet flushometer – 1.6 gpf (6.0 lpf)		<input type="checkbox"/> CP
K-13516	Manual toilet flushometer – 1.6 gpf (6.0 lpf)		<input type="checkbox"/> CP

Product Specification

The elongated toilet bowl shall be made of vitreous china. Bowl shall be 27-1/2" (699 mm) in length, 14-1/2" (368 mm) in width, and 15" (381 mm) in height. Bowl shall have 11" (279 mm) by 9-1/2" (241 mm) water area. Bowl shall have a 4-1/2" (114 mm) rough-in with a 1-1/2" top spud. Bowl shall feature 1.6 gpf (6.0 lpf), a 2-3/8" (60 mm) passageway, and an angle back and wall outlet. Elongated toilet bowl shall be Kohler Model K-4386-____ or K-4386-L-____.

ANGLESEY™

Technical Information

Fixture:	
Configuration	top spud, elongated
Water per flush	1.6 gpf (6.0 lpf)*
Spud size	1-1/2"
Passageway	2-3/8" (60 mm)
Water area	11" (279 mm) x 9-1/2" (241 mm)
Water depth from rim	5-1/4" (133 mm)
Seat post hole centers	5-1/2" (140 mm)
Minimum static pressure required	35 psi (241.3 kPa)
Maximum static pressure	80 psi (551.6 kPa)
Minimum flowing pressure required	25 psi (172.4 kPa)
Required supply minimum	25 gal/min (94.6 l/min)
* Based upon use of a 1.6 gal (6.0 L) flushometer.	

Included components:

Spud	18357
Floor screws (pair)	21402
Bolt cap accessory pack	1013092

Installation Notes

Install this product according to the installation guide.

Refer to manufacturer and local codes for flushometer requirements.

For back-to-back toilet installations: Use only a 45° double wye fitting.

Will comply with **CSA B651** when installed per Clause 4.3.6 of the standard.

Will comply with **OBC** when installed per Clause 3.8.3.8 and 3.8.3.9.

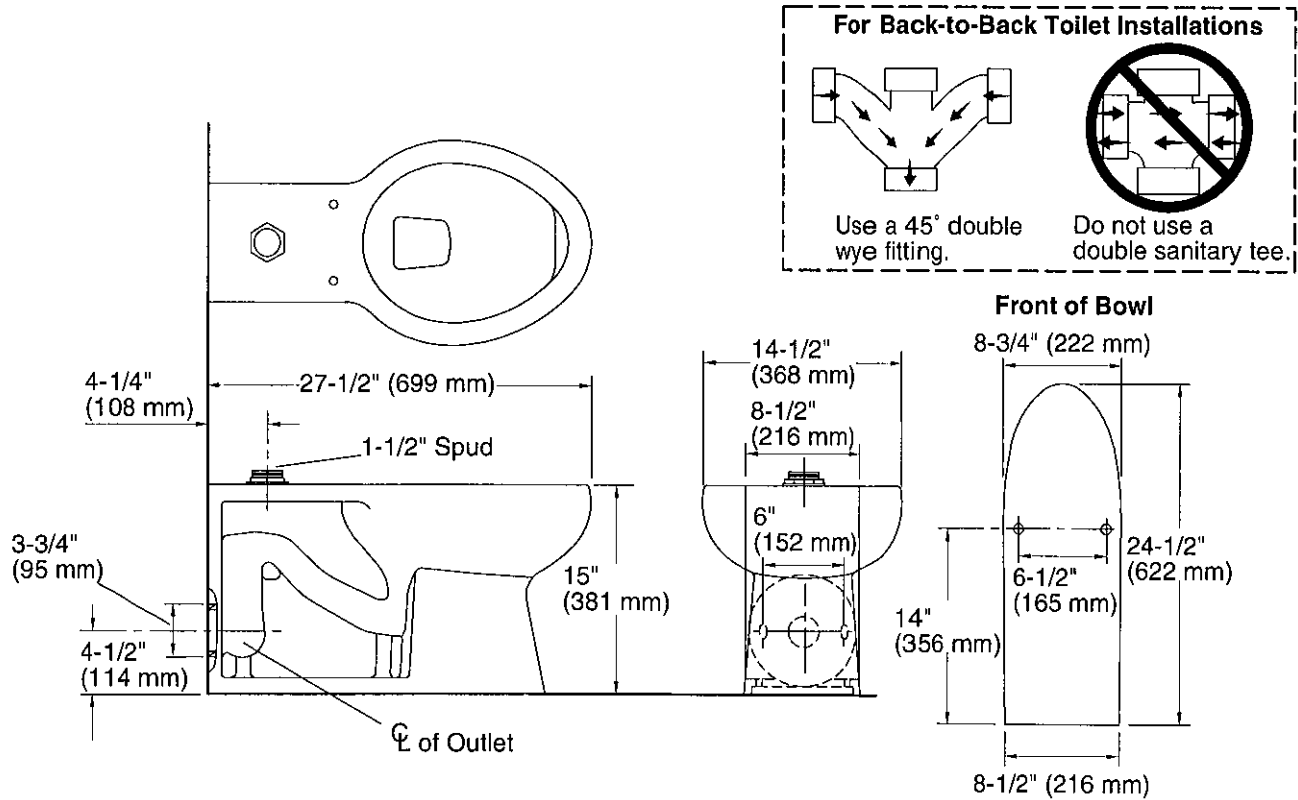

Product Diagram

**Exhibit B
Insurance**

Unless otherwise instructed in writing by the City, the Contractor shall obtain and maintain during the term of the Project and the Contractor Services Contract the insurance coverages at least equal to the coverages below, and as further provided in the General Conditions, but no event less than the individual and combined sovereign immunity limits established by Section 537.610 R.S.Mo. Insurance policies providing required coverages shall be with companies licensed to do business in the State of Missouri and rated no less than AA by Best or equivalent. All costs of obtaining and maintaining insurance coverages are included in the proposal and no additional payment will be made therefor by the City.

Comprehensive General Liability Insurance (including coverage for Bodily Injury and Property Damage)	\$505,520 per occurrence \$3,370,137 aggregate
Comprehensive Automobile Liability Insurance (including coverage for Bodily Injury and Property Damage)	\$505,520 per occurrence \$3,370,137 aggregate

In addition, the Contractor and all subcontractors shall provide Worker's Compensation Insurance in at least statutory amounts for all workers employed at the Project site. Unless instructed otherwise, the Contractor shall also provide a policy of Builder's Risk Insurance in the amount of 100% of the complete insurable value of the Project, which policy shall protect the Contractor and the City, as their respective interests shall appear. Before commencing any work, the Contractor shall provide to the City certificates of insurance evidencing the issuance and maintenance in force of the coverages required by this Exhibit D. Each such certificate shall show the City, and such other governmental agencies as may be required by the City to be insured by underlying grant or contract relating to the Project, as an additional insured, and shall bear an endorsement precluding cancellation of or change in coverage without at least thirty (30) days written notice to the City. Any self-insurance or deductible above \$50,000.00 is not permitted.

The City may waive any insurance coverages or amounts required by this Exhibit when the City deems such waiver may be in the interest of the public health, safety, and general welfare.